



# Online Monitoring of Transmission Line Impedances using PMU

Tariq Rahman,  
[TRahman@semprautilities.com](mailto:TRahman@semprautilities.com)

Hassan Ghoudjehbaklou,  
[HBaklou@semprautilities.com](mailto:HBaklou@semprautilities.com)

Subburaman Sankaran,  
[SSankaran@semprautilities.com](mailto:SSankaran@semprautilities.com)

Vahid Salehi,  
[VSalehi@seucontractor.com](mailto:VSalehi@seucontractor.com)

## San Diego Gas & Electric

### North American Synchrophasor Initiative



# Application of Transmission Line Impedances for Power System Studies

## Planning

- Power Flow, Short Circuit, Transient and Dynamic Stability, etc.

## Protection & Control

- Relay settings, Protection Coordination, Fault Analysis

## Operation

- EMS model, State Estimation, Line Rating, Post-Event Analysis

# Sources of Inaccuracy in Transmission Line Impedance Calculation

- Inaccurate length of the entire line: tower placement, spans, landscapes
- Less than ideal match between construction and a design plan and non-uniform implementation of line configuration of the transmission line,
- Environmental effect: temperature, wind, humidity, grounding and soil resistivity, solar radiation, line elevation, etc.
- Electric and magnetic effects: Mutual coupling from parallel lines or other magnetic fields, loading and aging (derating)
- Applying lots of Assumptions and Neglecting key and/or minor Parameters

# Offline Impedance Measurements

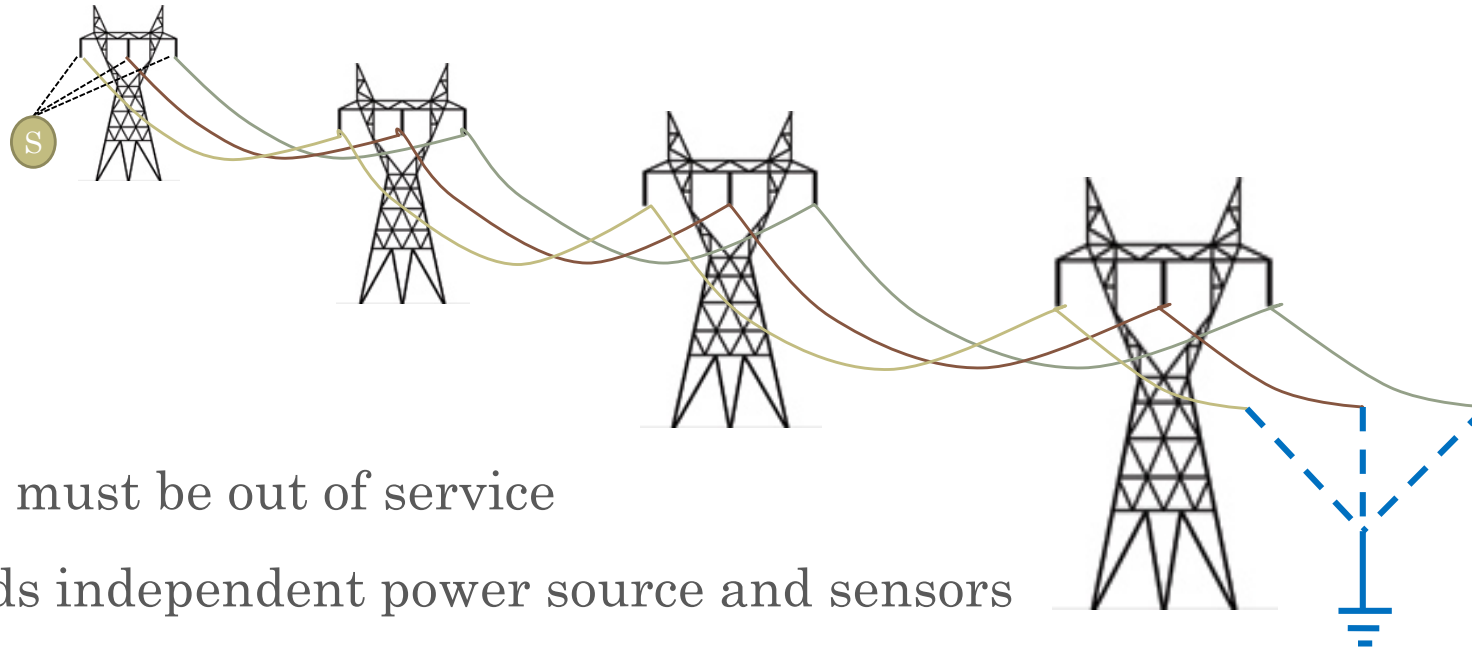

- Line must be out of service
- Needs independent power source and sensors
- (Pros) Results are accurate
- (Cons) Results are for the current ambient conditions and power source characteristics (i.e. frequency and magnitude, ...)

# Online Impedance Measurement

- Using PMUs in both ends of the line
- No need to disconnect the line (loads remains energized)
- No power source/switch control are required
- Covers all real-time ambient conditions, No assumptions

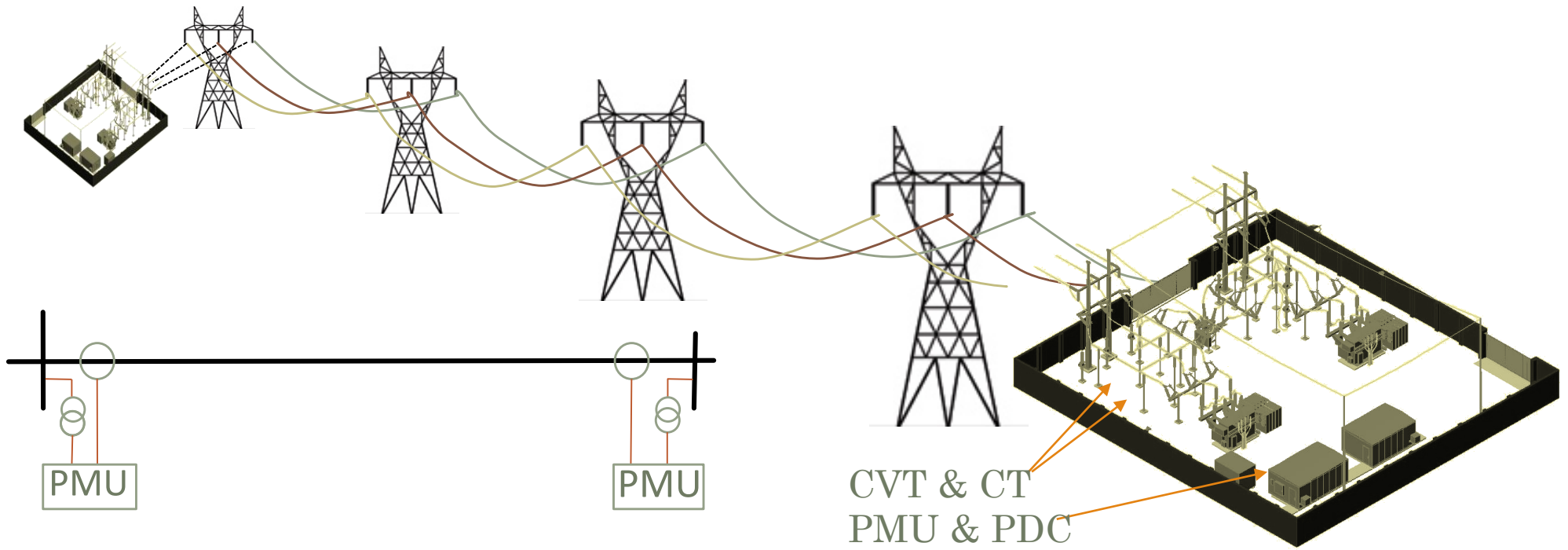

# Real-time Calculations of Positive Sequence Impedances

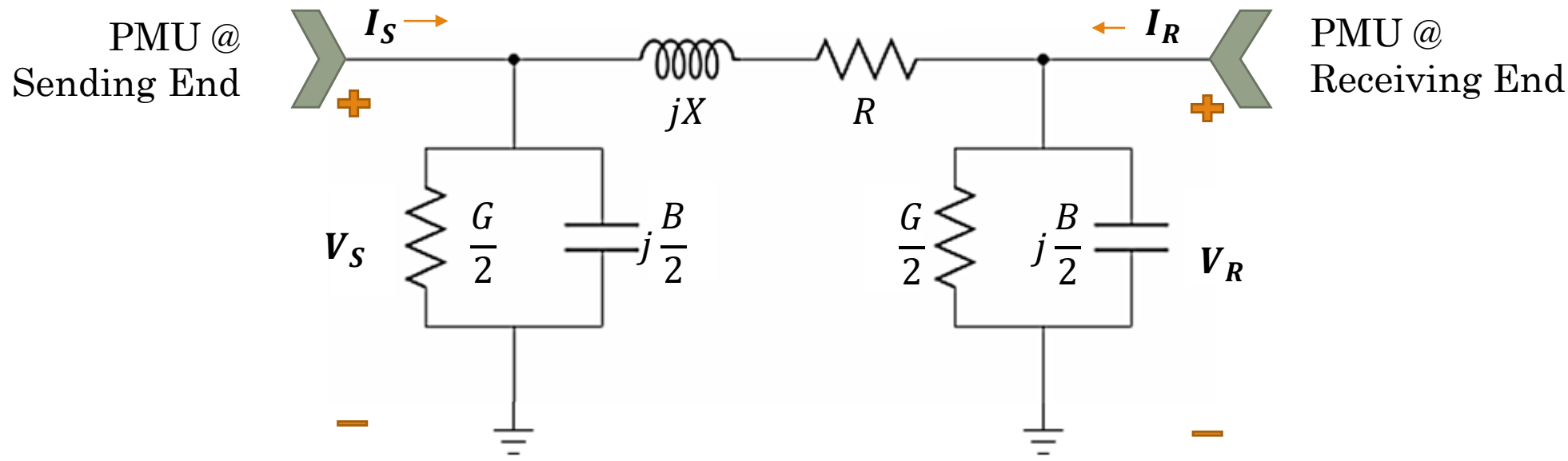

$$Z = R + jX = \frac{(V_s^2 - V_r^2)}{(V_s \times I_r + V_r \times I_s)}$$

$$Y = G + jB = \frac{2(I_s - I_r)}{(V_s + V_r)}$$

- Voltages and Currents are Positive Sequence Phasors
- All measurements are synchronized
- Assumptions: Line is ideally transposed  
No mutual effect

# Implementation on Real-time Application

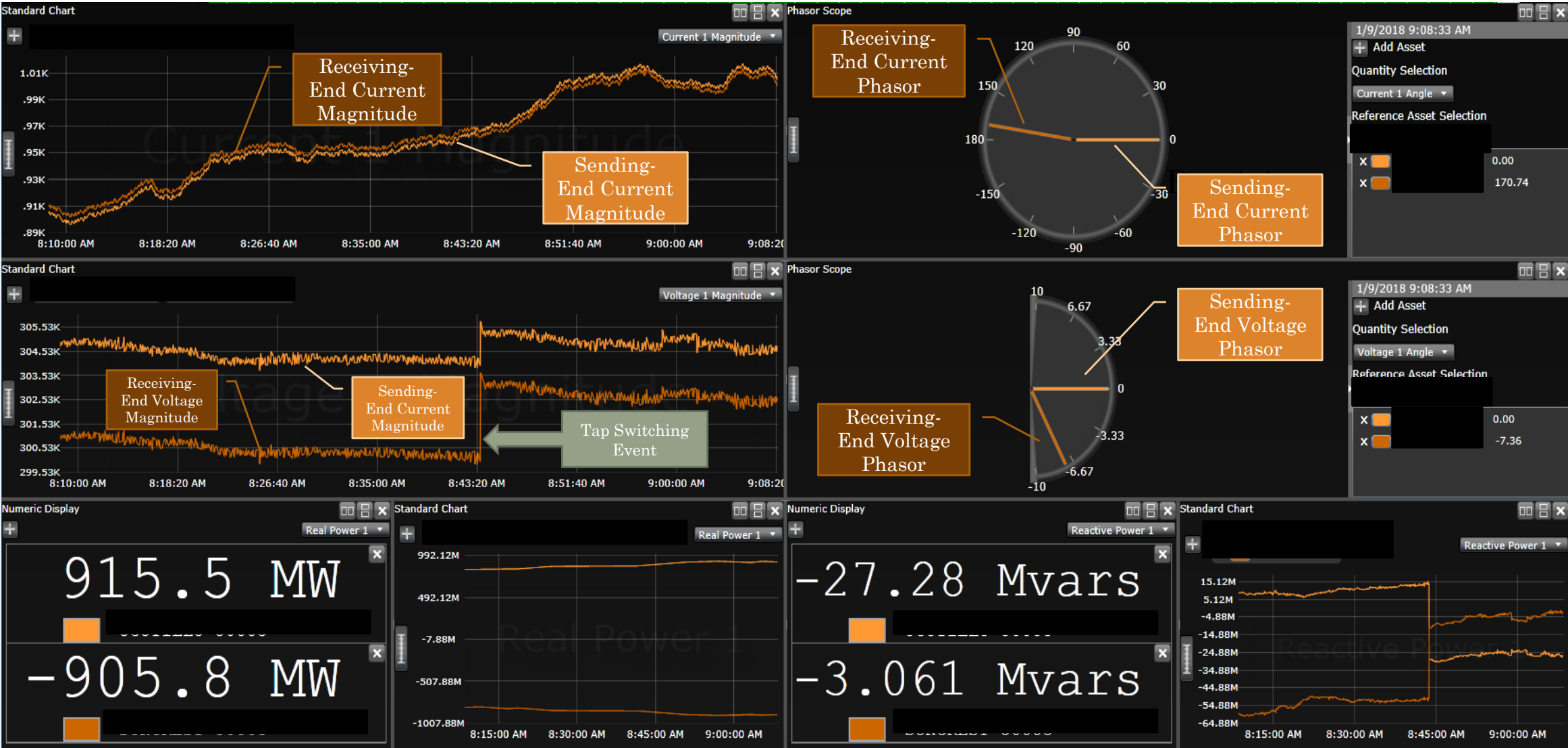

# Implementation on Real-time Application

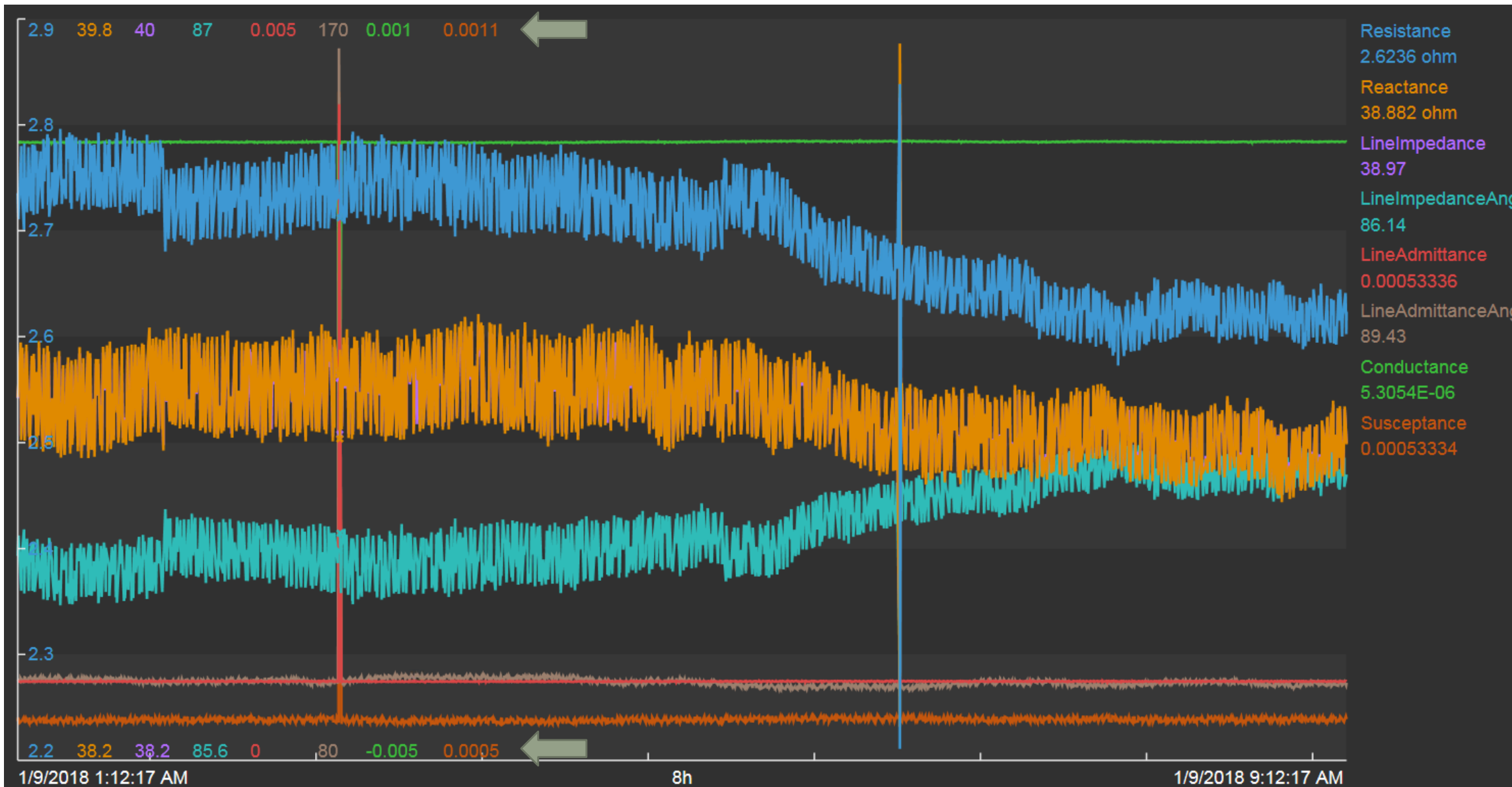



# Impedance Calculation at SDG&E

- Implemented on all SDG&E 500 kV and 230 kV' lines
- No filtering has been applied
- Any time frame can be selected
- All the impedances are archived and can be investigated off-line
- Variation over time on the electrical and environmental changes can be studied

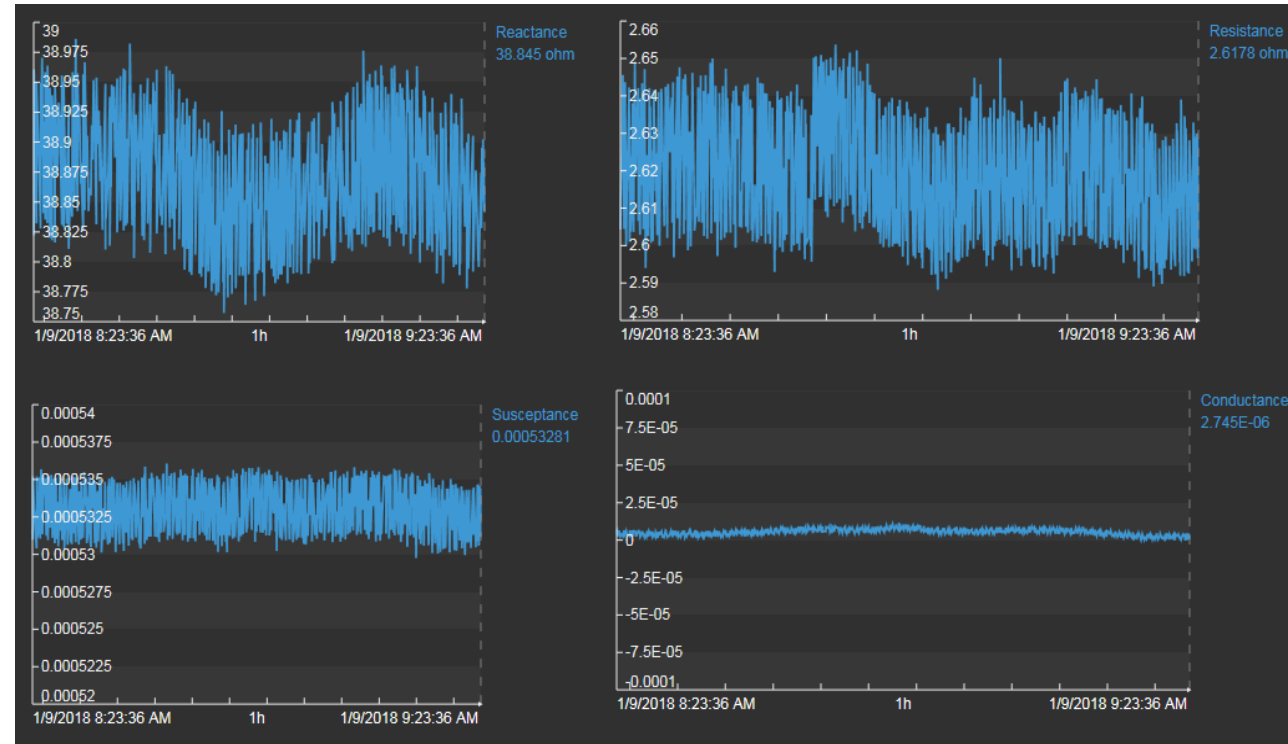

- Since Reactance and Susceptance are frequency dependent, they can be normalized to reflect values in 60 Hz nominal frequency
- Range of variations determines the accuracy of the measurements

# Impedance Calculation at SDG&E

Conductance  
6.0499E-06

Line Admittance  
0.00053256

Line Admittance Angle  
89.349

Line Impedance  
38.942

Line Impedance Angle  
86.136

Reactance  
38.854 ohm

Resistance  
2.6242 ohm

Susceptance  
0.00053252

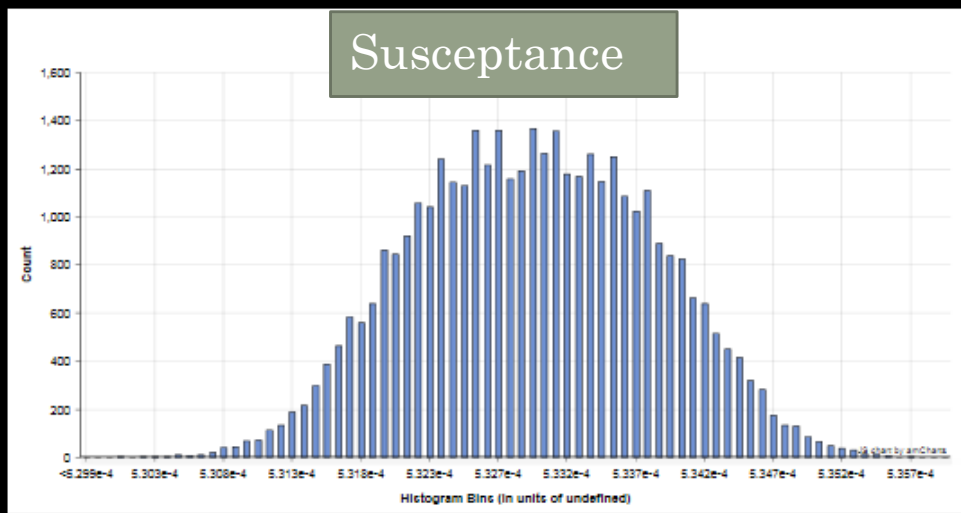
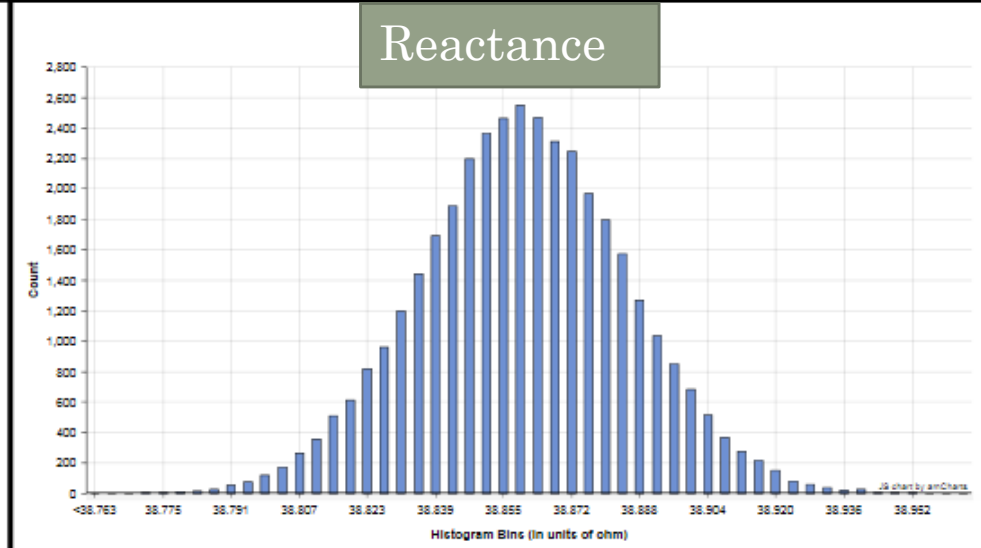
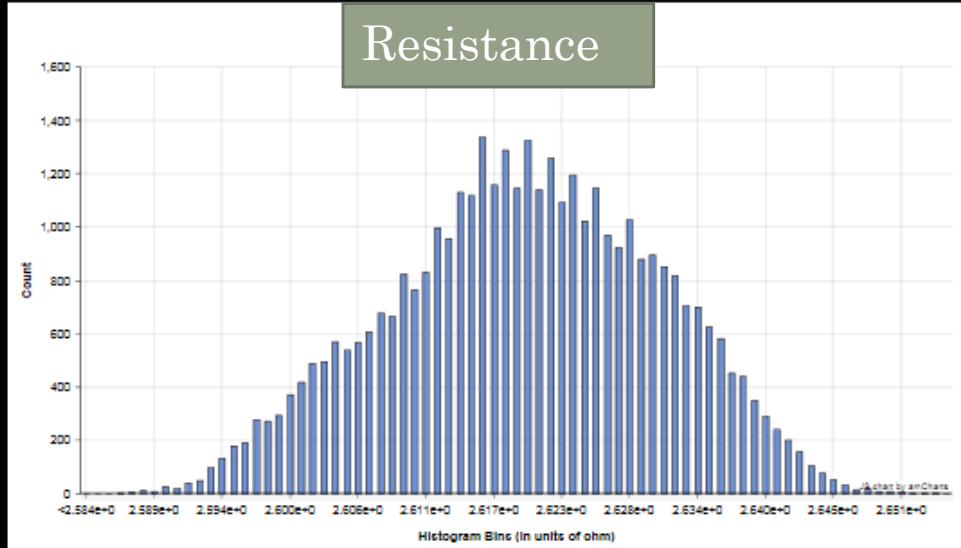

# Design versus Real-time Results

Parameter	Design Data	Real-Time	%Variation
<b>Resistance</b>	2.3 Ω	2.62 Ω	+13.91%
<b>Reactance</b>	35.575 Ω	38.86 Ω	+9.23%
<b>Impedance</b>	35.649 Ω	38.94 Ω	+9.23%
<b>Impedance Angle</b>	86.30°	86.14°	-0.18%
<b>Conductance</b>	0	$6.05 \times 10^{-6} \text{ } \bar{U}$	-
<b>Susceptance</b>	0.000576 $\bar{U}$	0.000531 $\bar{U}$	-7.81%
<b>Admittance</b>	0.000576 $\bar{U}$	0.000531 $\bar{U}$	-7.81%
<b>Admittance Angle</b>	90°	89.34°	-0.73%

# Findings:

- Impedances have almost normal distribution shape when the plotted histogram uses shorter time frame not to experience intense weather or loading variations. Hence, its maximum point can be considered as the most reliable measurement.
- Resistance and conductance are depended on temperature, based on metal conductors inherited characteristic. Therefore, distribution over the longer time frame is a combination of several or many normal distributions. We are anticipating slow and continuous ambient temperature changes (hour scale), but loading of the line can be changed suddenly based on the network reconfiguration and makes conductors' temperature to rise/fall quickly (minute scale).

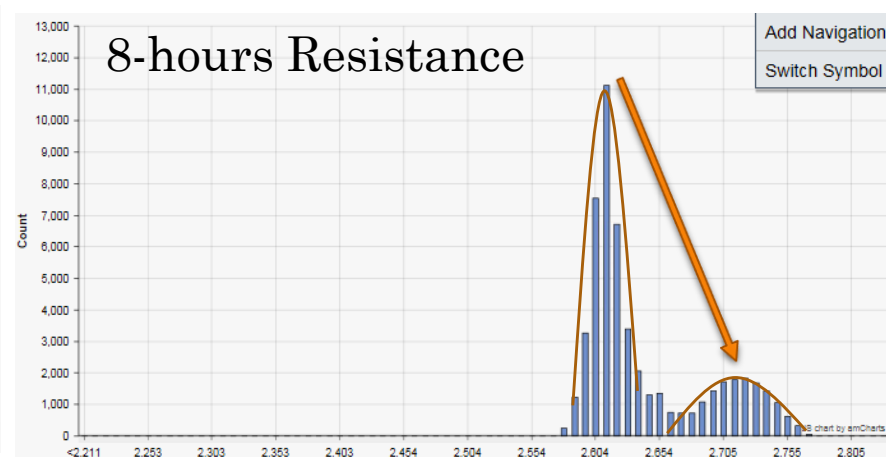
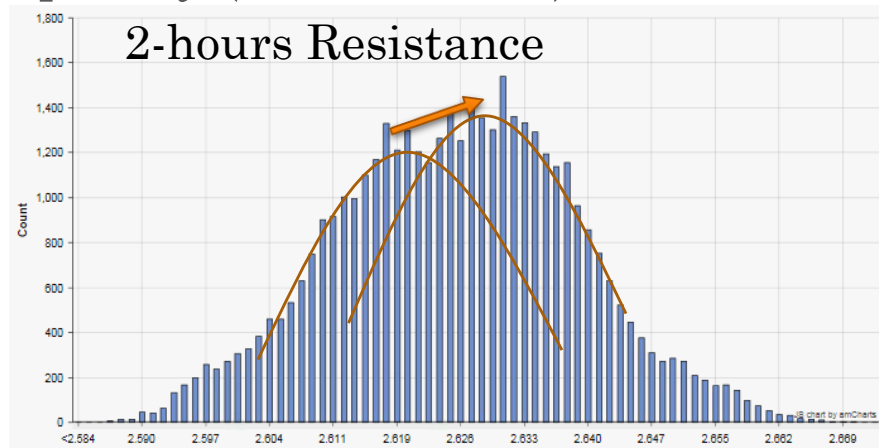

# Findings:

- Reactance and Susceptance are dependent on frequency, so we normalized them to reflect reactance at exact 60 Hz.
- Normalized reactance didn't help to narrow down the range of reactance variation considerably
- It helps to fit the normal distribution
- Reactance seems to have almost the same distribution over the time; this means it is independent to weather condition or loading of the line

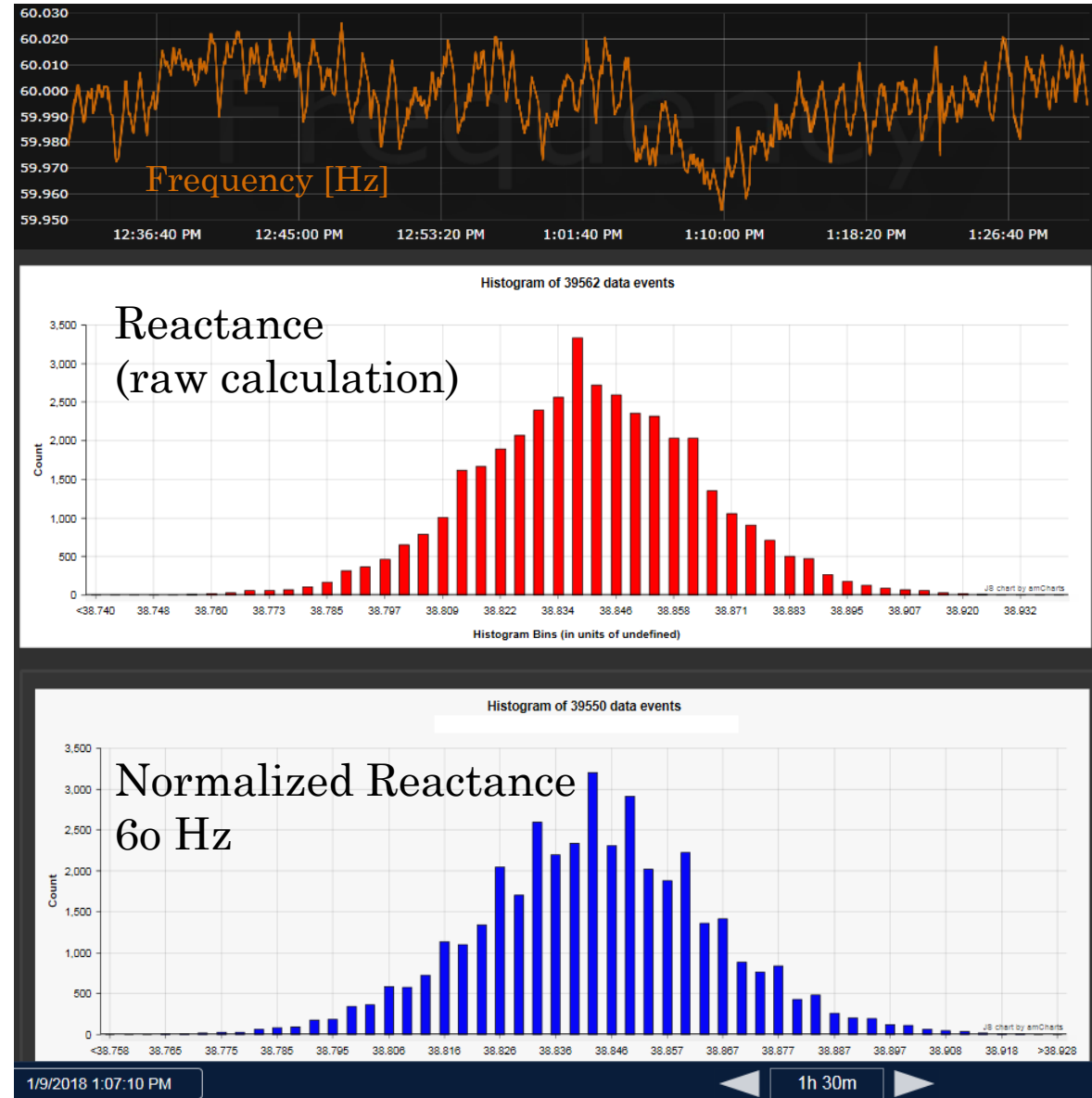

# Recursive Moving Averaging:

- Applying Recursive Moving Average can lower impedance measurements ripple considerably
- The value of  $n$  is a trade-off between having lower variations' depth and tracking rate of the original signal

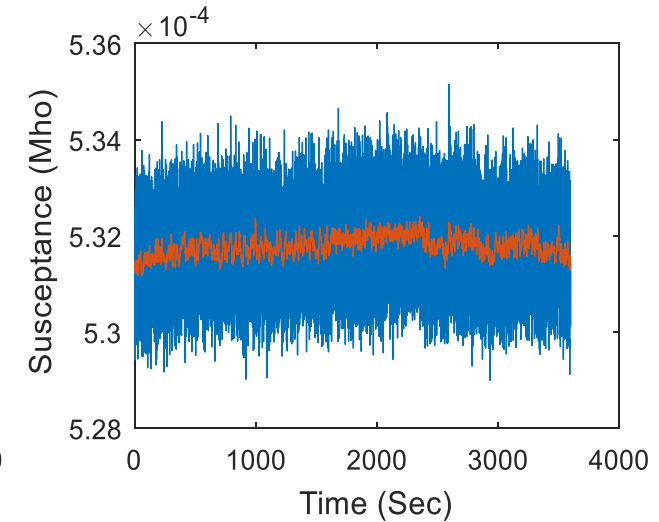
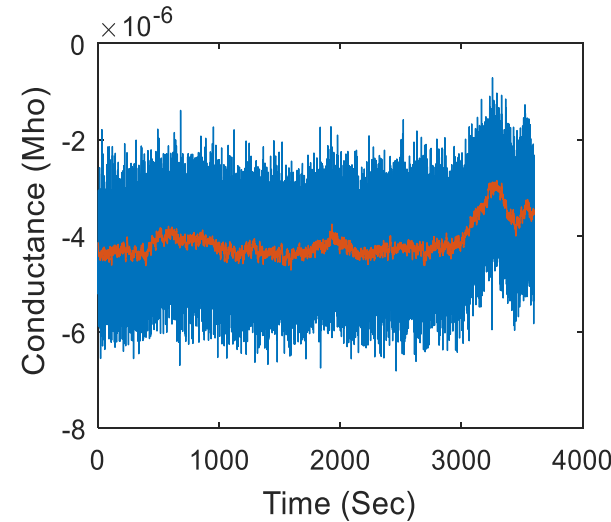
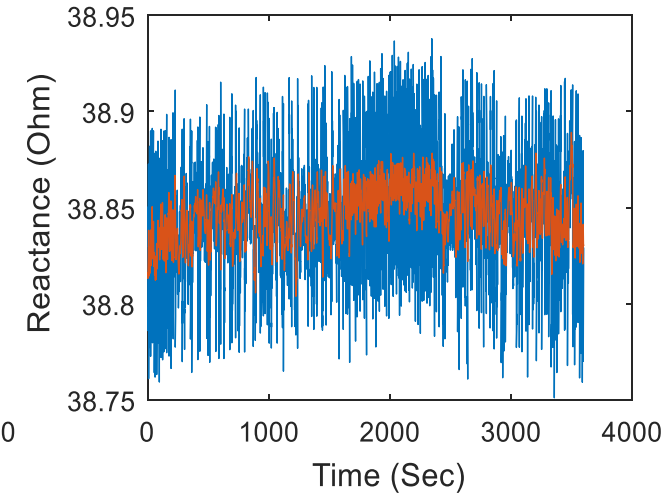
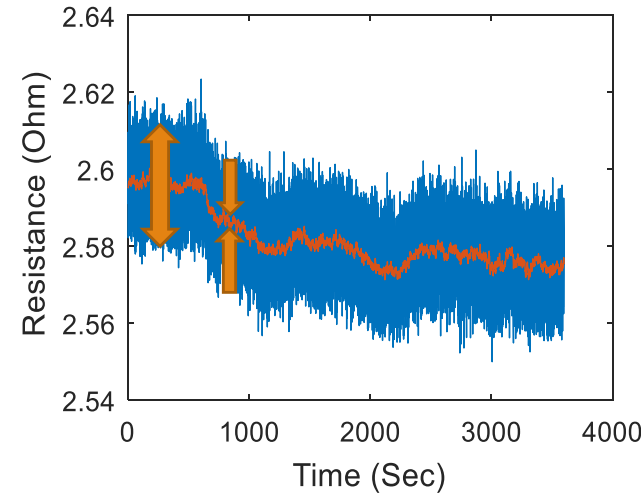
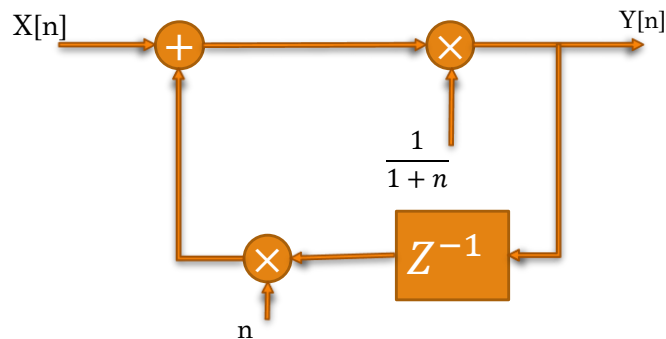

Recursive Windows  $n=100$  Samples

# Implementation Considerations and Limitations

- Similar to other measurements, Impedances are strongly reliant on CTs and PTs accuracy. Any miscalibrated device will be the source of inaccuracy and will lead to the wrong calculation results. Before running impedance calculation we have to make sure all measurements are calibrated and accurate. Calibration issues have been seen in some lines. It was apparent in input/output active power which made power loss negative. In this case, inaccuracy led to negative calculated line resistance.

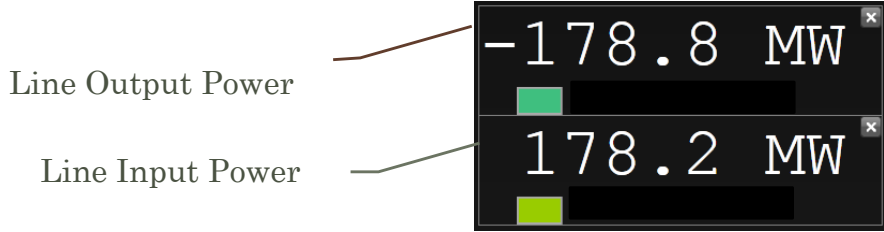

- Voltage and Currents measurements should be under CTs and PTs accuracy range. In another word, the line should be loaded enough (above 10%) to have impedances calculated accurately. On the other hand, during the system events such as switching caps, breakers or short circuits which leads to the severe voltage/current transients, calculated impedances are not reliable.

# Implementation Considerations and Limitations

- One of the sources of inaccuracy was PMUs setting discrepancy between both ends of line. Floating point versus Integer data types generates
- For accuracy, all relays PMU settings should be set to float data type.

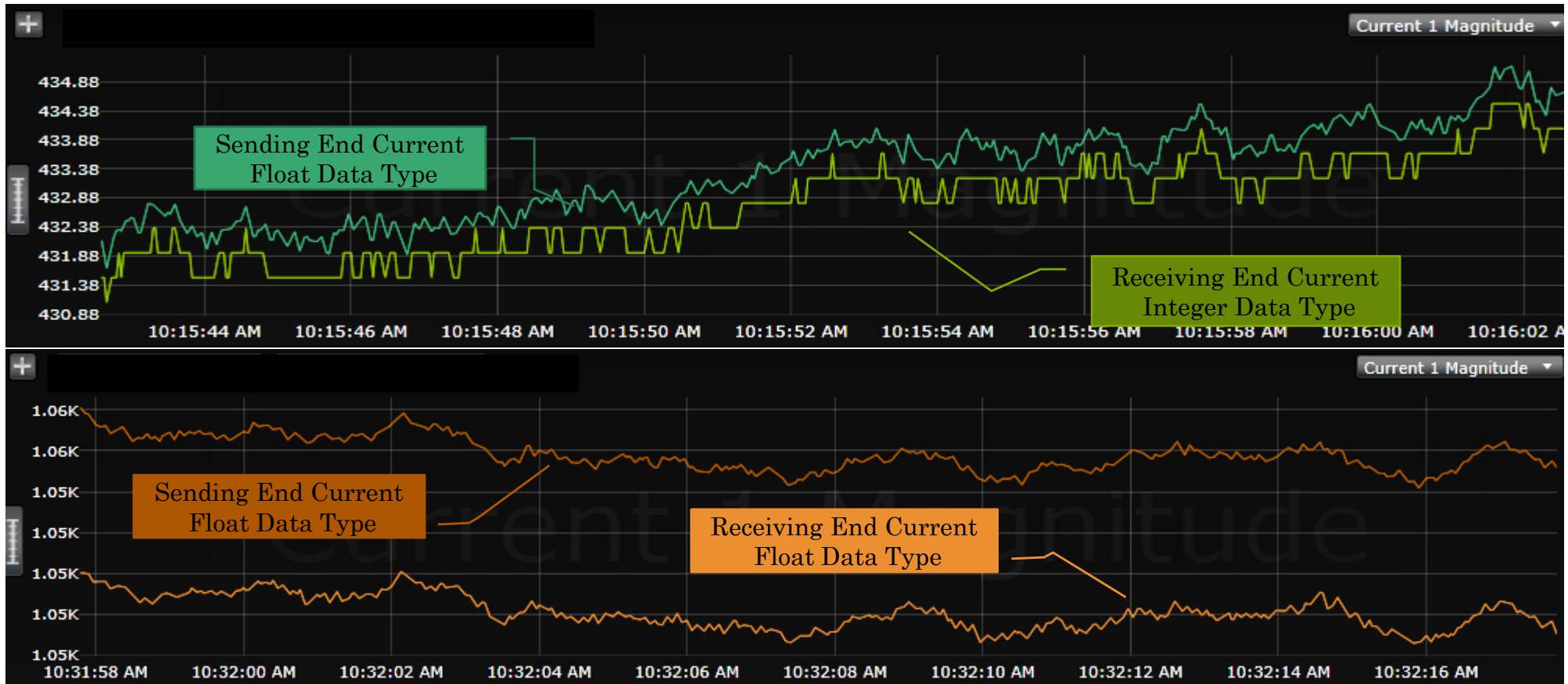



# Implementation Considerations and Limitations

- SDG&E has several of 3-Terminal Lines tied in somewhere in the middle. Each terminal has its own PMU at the substation.
- The applied formula is not applicable to 3-terminal lines.
- If the lines types are similar (same conductor/tower) then impedances per length will be same for all 3-sections. Therefore there will be a solution using all three PMU real-time data.
- If line sections had different line types, there would be more unknowns than knowns parameters, and hence LSE (least-squares error) method or a complicated algorithm should be applied. It would need a couple of past consecutive samples to calculate impedances.
- SDG&E is still investigating different approaches

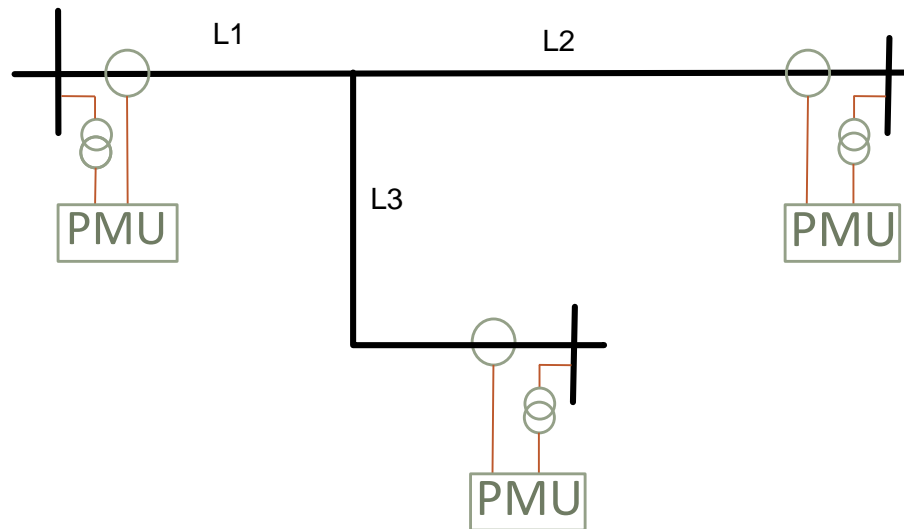

# Zero Sequence Impedance

- The approach is assuming pi-model and ideally transpose line, corresponding model in all software and power system studies.
- Simple and effective method to calculate zero sequence impedances:

$$Z_o = R_o + jX_o = \frac{(V_o^s{}^2 - V_o^r{}^2)}{(V_o^s \times I_o^r + V_o^r \times I_o^s)}$$

$$Y_o = G_o + jB_o = 2 \times \frac{(I_o^s - I_o^r)}{(V_o^s + V_o^r)}$$

- Zero sequence Voltage and Currents should be extracted from all three phase voltage and current phasors.

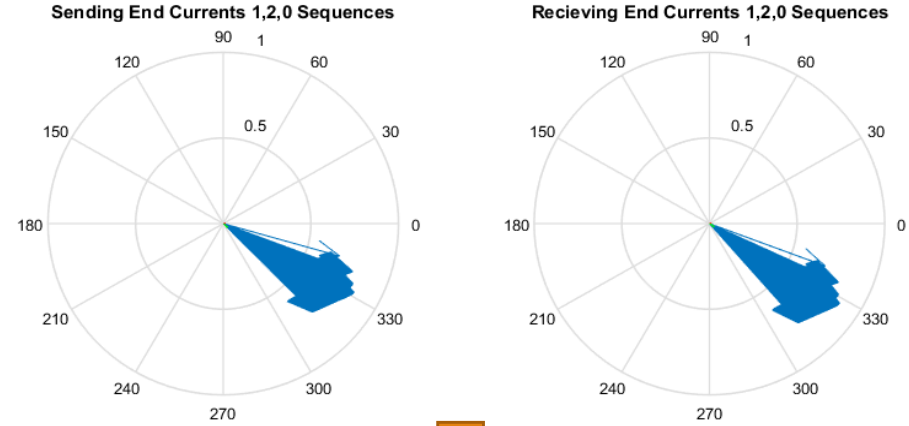

**Zoomed in**

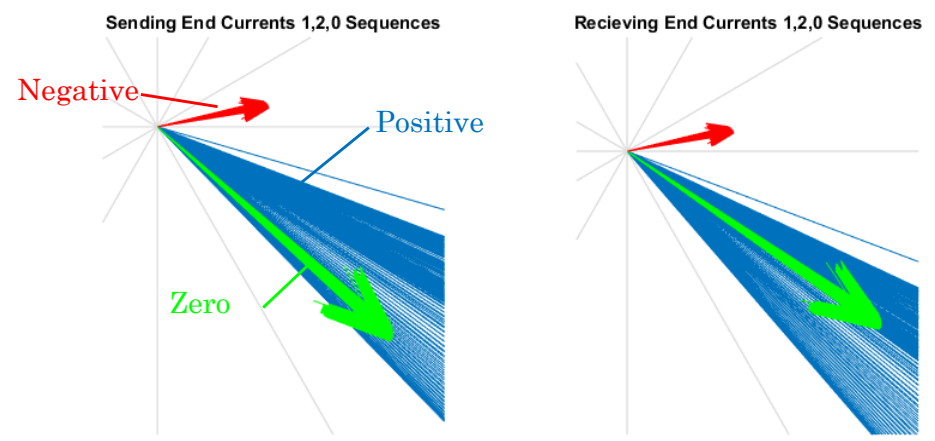

# Zero Sequence Impedance

- More considerable variations in the calculated impedances are due to low zero sequence voltage/current measurements. Therefore, real-time PMU measurements don't seem promising approach.

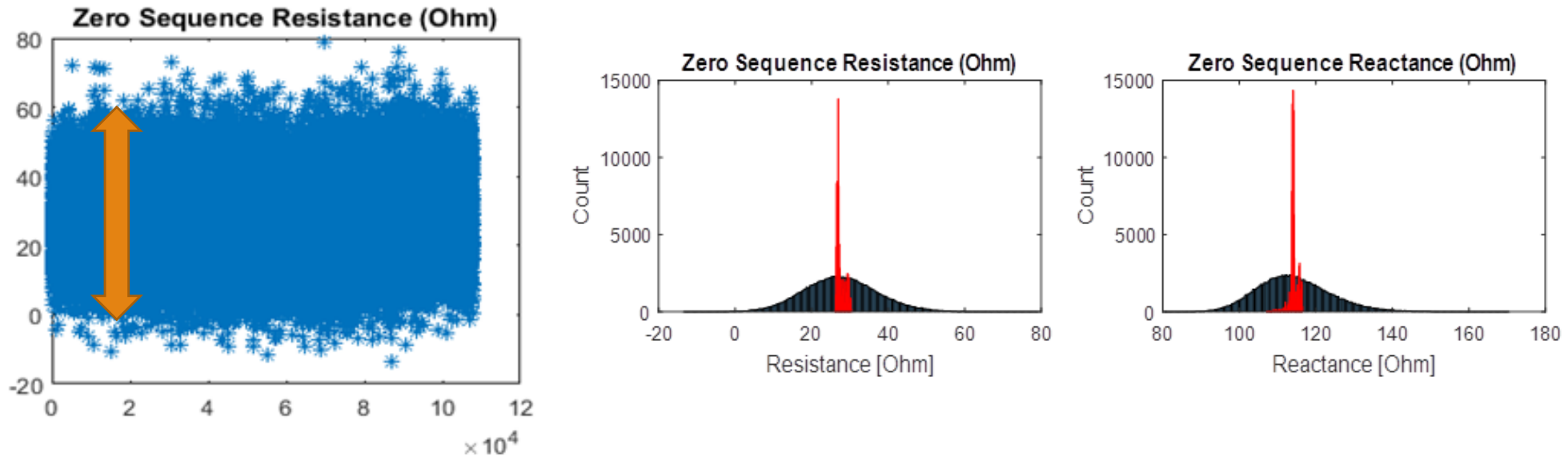

- Other methods including LSE for ideally and not-ideally transposed lines have been investigated offline but didn't provide any advantage and reasonable results over the applied practice.

# Future Plans

- Utilize the real-time impedances to update, verify and validate power system models for power flow, short circuit, protection coordination transient stability, voltage stability and state estimation models. Also, validating the measurements that are used in relays and other online applications.
- Apply updated and verified results into Relays settings.
- Apply real-time impedances in real-time applications such as State Estimation, Voltage Stability, etc.
- Implement new PMU applications which use realistic real-time impedances.
- Design and Implement “Dynamic Line Ratings” using Synchrophasor data along with real-time weather data (under investigation.)

L23066	1.68	505	44.2
L23042	-	413	35.2
L50001	6.25	945	34.7
L23022	-	157	33.3
L23055	3.91	296	32.4
L23023	3.24	153	32.5
L50004	3.46	922	31.2
L23026	1.34	317	27.0
L23013	1.06	195	24.5
L50003	4.49	565	23.3
L23029	0.20	102	22.3
L50005	1.40	569	19.8
L23001	4.60	69	15.1
L23004	4.61	60	15.1

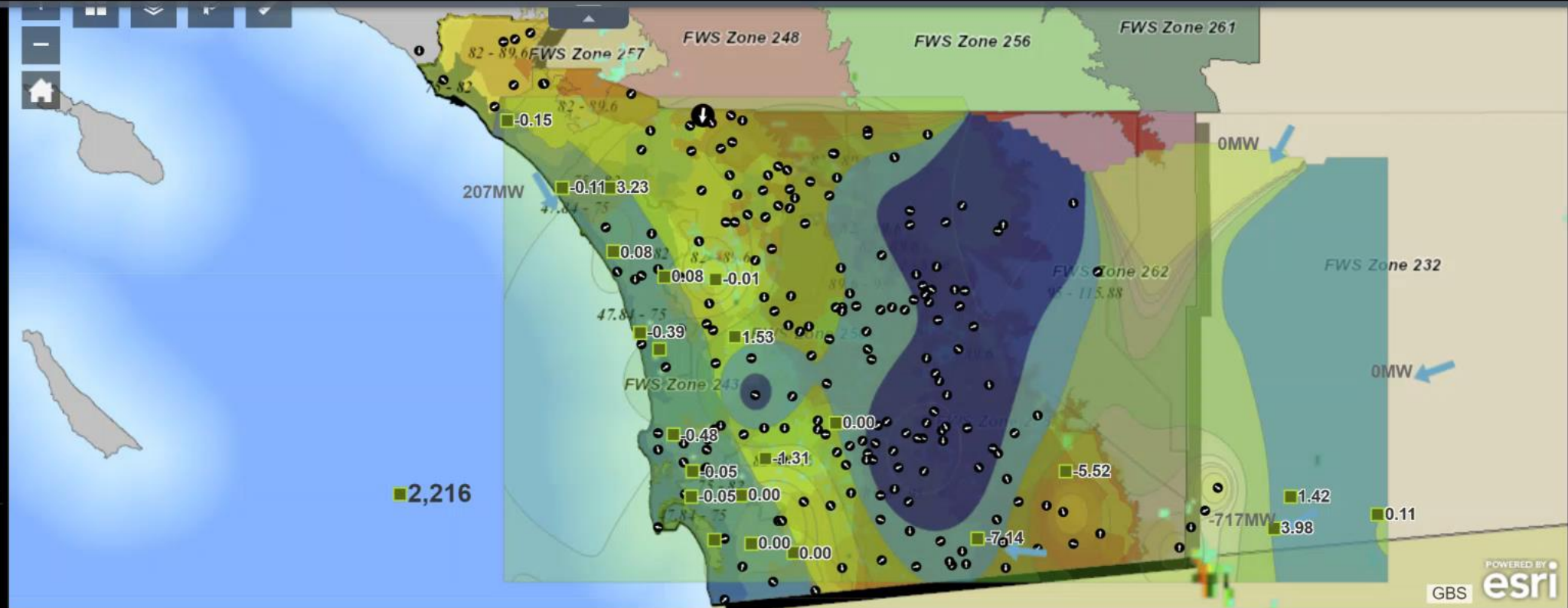

PMU Frequency  
**59.99 Hz**

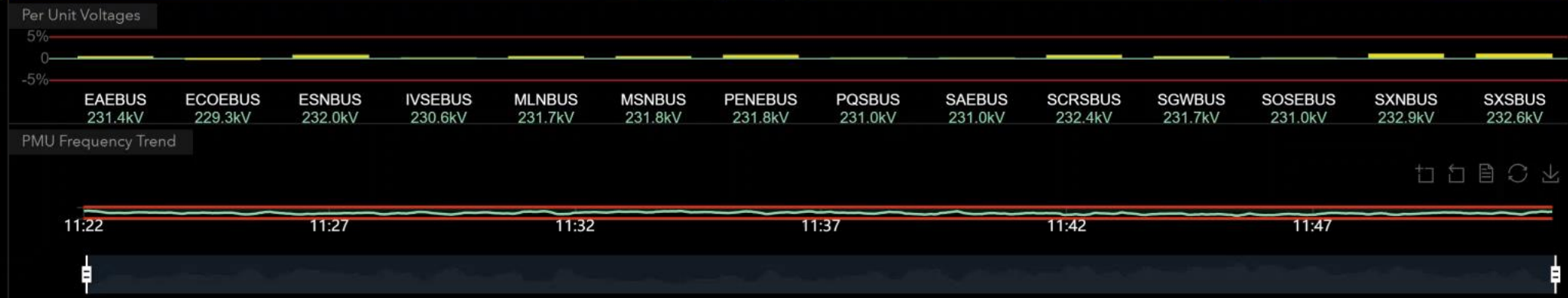
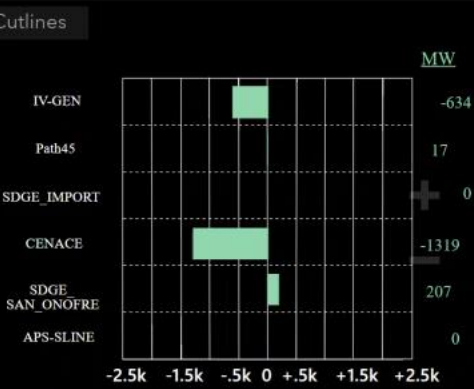

# Questions and Discussion

